

LEVEL SENSOR WITH TRANSMITTER

4-20 mA (9 meters)

DESCRIPTION:

CODE: 06140244

Transmitter that converts the distance measurement provided by an ultrasound sensor to a standard 4-20 mA output. The output current is referenced to the "0V" of the transmitter power supply.

The ultrasound sensor is supplied together with the transmitter. It is a sensor that provides distance measurements from 500 mm to 9000 mm. With this transmitter, the 4-20 mA signal can be adjusted to the desired distance measurement range.

The transmitter is housed inside an ABS plastic case. The set has an IP65 tightness.



TECHNICAL CHARACTERISTICS:

Power	Minimum	10.5 Vdc
	Typical	12 Vdc
	Maximum	15 Vdc
Consumption	Maximum	45 mA (DC)
Protections	Reverse current	Yes
	Overvoltages	Yes
Number of inputs / outputs	1	
Minimum measuring distance	500 mm	
Maximum measuring distance	9000 mm	
Minimum diameter (Wells-rafts)	1 meter	
Input signal	0-5 V (Ultrasonic sensor output)	
Output signal	4-20 mA (about 0V of power)	
Maximum output cable distance	500 meters (cable 0.5 mm ²)	
Maximum load resistance	235 Ω (at 12 Vdc)	
Response time	1 second (minimum power time to operate)	



This symbol indicates that the electrical and electronic equipment should not be disposed of as general household waste at its end-of-life. Instead, the product should be handed over to the applicable collection point for the recycling of electrical and electronic equipment for proper treatment, recovery and recycling in accordance with your national legislation.

TRANSMITTER INSTALLATION:

The ultrasonic sensor is directly connected to the transmitter through a PG-9 cable gland. This sensor has the following interface:

Power (blue wire)	➔	E1 (+5 Vdc)
Reading-level (brown wire)	➔	E3 (signal from 0 to 5 Vdc)
Ground (yellow-green wire and mesh)	➔	E4

Transmitter power and measurement (port A) can be done from a 3-wire cable that will enter through another PG-9 cable gland.

The box has a fixing system with two 4 mm holes that can support self-tapping screws for fixing to the wall of base. It is accessed by removing the cover.

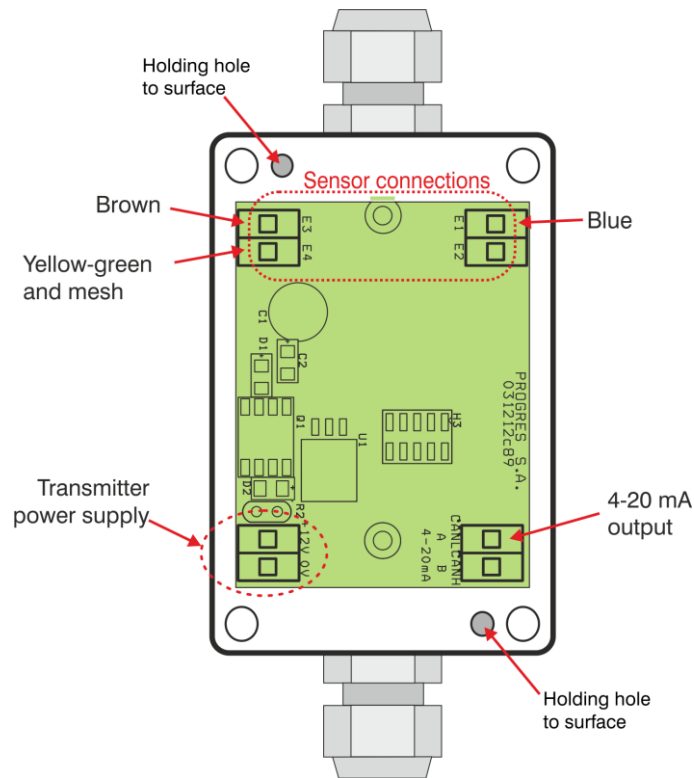

SENSOR INSTALLATION:

The ultrasound sensor must always be installed at a distance greater than 50 cm from the closest surface to be measured. In the case of a tank, the sensor must be located at more than 50 cm from the maximum level it can reach.

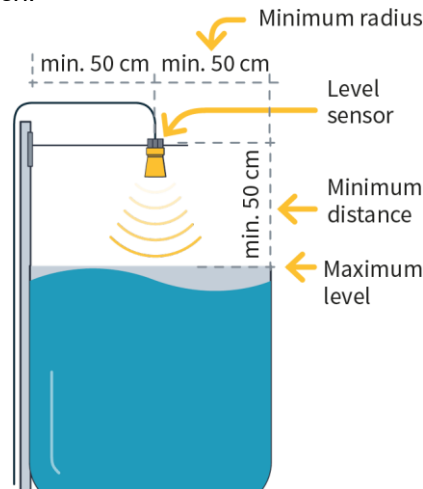

The sensor is supplied with 7 meters of cable that is already connected to the transmitter, so there is no need to make any additional connection. A sensor support is also supplied to facilitate sensor installation.

Sensor mounting and location:

- 1.- The sensor must be well fixed in its location by means of the provided support. It is important that it is well supported and does not have any type of movement, since this would alter the result of the measurements.
- 2.- There should be no objects between the sensor and the surface to be measured.
- 3.- Do not place the sensor next to a wall or to any other surface parallel to the central axis of the sensor. The **minimum distance** between the **sensor** axis and any parallel surface must be **50 cm**.

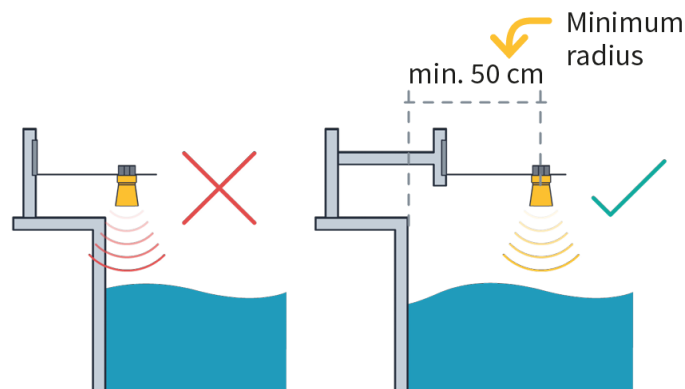

NOTE: The reference point of the sensor for measuring distances is the point at which the support is located, as indicated in the figure.



Reading point 0

ATTENTION: Since these sensors use sound to operate, **THEY DO NOT WORK UNDER VACUUM CONDITIONS**, since in vacuum there is no air for sounds to propagate.

WELLS/RAFT LEVELS:

This sensor measures direct distances. However, for applications where you want to know the level of a well or raft, you can adapt the format defined for the sensor, to obtain this direct measurement. For this, it is necessary to exactly know the distance between the base of the sensor and the bottom of the raft; and the distance between the sensor base and the maximum level of the raft.

The following table shows the setting of the sensor format according to the distance from the sensor to the bottom of the raft or well (for other distances not shown in the table, consult the factory):

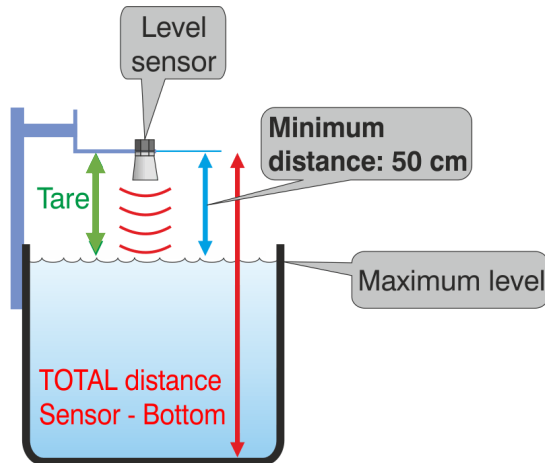

Total distance Sensor-Bottom_Raft [mm]	Point1 (4mA) True Value [mV]	Point1 (4mA) Logical value [mm]	Point2 (20mA) True value [mV]	Point2 (20mA) Logical value [mm]	Tare ⁽¹⁾ [mm]
2000	800	2000	1365	500	-500
2500	800	2500	1553	500	-500
3000	800	3000	1741	500	-500
3500	800	3500	1929	500	-500
4000	800	4000	2118	500	-500
4500	800	4500	2306	500	-500
5000	800	5000	2494	500	-500
5500	800	5500	2682	500	-500
6000	800	6000	2871	500	-500
6500	800	6500	3059	500	-500
7000	800	7000	3247	500	-500
7500	800	7500	3435	500	-500
8000	800	8000	3624	500	-500
8500	800	8500	3812	500	-500
9000	800	9000	4000	500	-500

NOTE (1): The tare value will be negative and will correspond to the distance between the sensor and the maximum level of the raft. If the sensor is installed at just 500 mm from the maximum level, this tare will be the value shown in the table.

Sistemes Electrònics Progrés, S.A.

Polígon Industrial, C/ de la Coma, 2
25243 El Palau d'Anglesola | Lleida | España
Tel. 973 32 04 29 | info@progres.es

www.progres.es

R-2267