

AgroBee-L 3MA System

Very low consumption radio modules and integral components of the AgroBee-L system for reading sensors of any type with 4-20 mA or 0-20 V outputs, and for reading digital sensors.

The AgroBee-L 3MA model offers the following:

- 3 analog sensor inputs:
 - 2 4-20 mA inputs
 - 1 4-20 mA or 0-20 Volt input
- 1 counter or digital sensor or rain gauge input

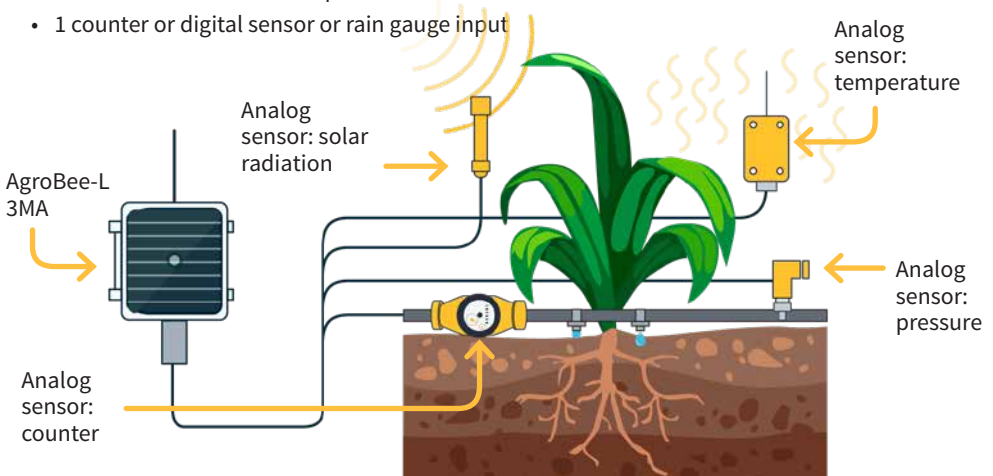

As an example, the 4-20mA sensors that this model manages can record temperature, pressure, trunk/fruit dilation, wind, radiation, etc.

This module is powered by a 1.6 W solar panel + supercapacitors, already incorporated into the controller (no need to replace batteries).

The number of analog sensors used (from 1 to 3) by a module can be set with Module Reader or from the controller to which the module is associated. The type of these for sensor 1 (4-20 mA or 0-20 V) must be configured from the Module Reader or from the controller; and in addition, the switches installed inside the module (sensor 1) must be fixed to the corresponding position.

Likewise, the supply voltage supplied to the analog sensors (5 Vdc or 12 Vdc) as well as the time during which the voltage is applied (250ms, 500ms, 1s, 2s) can also be configured from the Reader or from the associated controller.

These sensors' reading rates can be selected from 3 different values: 5, 10, or 20 minutes, with the default value being 5 minutes.

Technical characteristics

Alimentación

Power supply:	3MA: Solar: 5V / 1,6W → 3,3V	Panel plus high capacity supercapacitors
	3MA 220V o 12V: 12V or 220V/12V transformer → 3,3V	
Power Consumption: 3MA	Average consumption: 0.90 mW	

Outputs

Number	3
Type	5 Vcc ó 12 Vcc (Sensor power supply) Maximum current: 100 mA

Inputs

Maximum distance between sensor and AgroBee-L: 50m

Number	1
Type	For potential-free contacts
Number	3
Type	Analog (16 bits)

Environment

Temperature	-10 °C a +60 °C
Moisture	< 95 %
Altitude	2000 m
Pollution	Grade II

Box dimensions

	3MA	3MA 220V or 12V
Height	150 mm	150 mm
Width	150 mm	100 mm
Dept	90 mm	70 mm
Weight (approx.)	0,8 Kg	0,4 Kg

Declaration of conformity

This system conforms with the regulations and other regulatory documents in the following list:



Electrical safety	Low voltage directive 2014/35/EU	UNE-EN 62368-1:2014+AC:2015+AC1:2015+AC2:2015+AC:2017-03+A11:2017 Audio and video equipment, information and communication technology. Part1: Security requirements.
EMC	Directive 2014/53/EU	ETSI EN 301 489-1 Ver. 2.1.1 – <i>ElectroMagnetic Compatibility (EMC) standard for radio equipment and services; Part 1: Common technical requirements; Harmonised Standard covering the essential requirements of article 3.1(b) of Directive 2014/53/EU and the essential requirements of article 6 of Directive 2014/30/EU.</i> ETSI EN 301 489-3 Ver. 2.1.1 – <i>ElectroMagnetic Compatibility (EMC) standard for radio equipment and services; Part 3: Specific conditions for Short-Range Devices (SRD) operating on frequencies between 9 kHz and 246 GHz; Harmonised Standard covering the essential requirements of article 3.1(b) of Directive 2014/53/EU.</i>



This symbol indicates that electrical and electronic controller must not be disposed of along with household waste at the end of its useful life. The product must be taken to the corresponding collection point for the recycling and proper treatment of electrical and electronic controller in accordance with national legislation.

AgroBee-L System Operation

The AgroBee-L radio modules are used for the activation of valves and other irrigation elements, as well as the reading of sensors and meters. It is very low consumption and follows the LoRa radio modulation, which operates in the 868MHz, 433 MHz and 915 MHz, free bands, obtaining radio coverage of up to 2500 m between two points (depending on the orography).

Currently, they can be incorporated into the Agrónic 2500, Agrónic 4500, Agrónic 5500 and Agrónic Bit Con fertirrigation controllers.

The AgroBee-L system consists of a coordinator device (located in the Agrónic 2500, Agrónic 4500, Agrónic 5500 or Agrónic Bit Con controllers) and by field elements with different functions, depending on the model in question. This system does not include the use of repeater elements, so all modules must connect directly with their coordinator. The field modules manage their consumption by activating the communication in the precise time of the exchange; the rest of the time, they are asleep or attending to irrigation control.

Its low consumption allows it to operate with a solar panel integrated into the module and supercapacitors or battery (depending on the model). The solar panel stores the energy in the supercapacitors/battery, offering a long operational life. It is only necessary to replace batteries in models that include batteries instead of supercapacitors.

The maximum number of modules that an Agrónic controller can manage is 20 units in standard mode, which can be configured as modules of any of the available types. There is also a priority mode, which makes it possible for the modules to communicate more often: in this case, the number of modules (10) is halved.

To use AgroBee-L modules, it is necessary to assign their outputs to the sectors or generals of

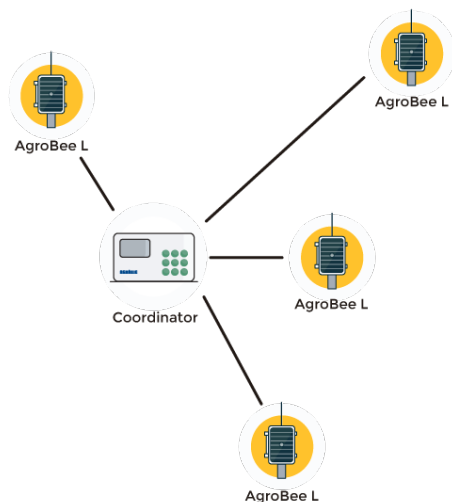

the controller in question, and their inputs to the digital, analog, or counters sensors.

The AgroBee-L system has the following features, among others:

- Operation in 868 MHz, 433 MHz and 915 MHz free bands.
- Availability of 13 communication channels plus 18 transmission modes, which allow for the operation of more than one network in the same area working on the same channel.
- Availability of network code, which allows for filtering the information of several networks configured with the same parameters.
- Self-adjustable communication rate according to the chosen transmission mode and the timing mode:
 - Timing in standard mode (60 –200”). Up to 20 modules.
 - Timing in priority mode (30 –100”). Up to 10 modules.
- Distances of up to 2500 metres between any module and its coordinator (depending on the orography).
- Manual actions, consultations, and configuration of the network number, channel, transmission mode, and communication timing (standard/priority):
 - In-situ: Through the Module Reader
 - From a distance: Through the Agrónic
- Battery/charge level reading and solar panel (if any).
- Reading SNR level (signal-to-noise ratio) reception in the module and coordinator (in [%]).
- Reading the status of the last 16 communications and remaining time indicator until the next communication.

Installation

For the supply of radio controller, it is essential to have a coverage study. This study verifies the viability of the system according to the profile of the terrain, the location of the points to be controlled, and the distance between them. The study is delivered along with the controller offer.

ELECTRÓNICA PROCES, S.A.

ESTUDIO DE COBERTURA RADIO

	El resultado del estudio es VIABLE	Número de estudio 2017 - 001	Fecha de creación 05/12/2017
	Referencia FINCA RO GRANDE		
	Instalador AGUAS DEL NORTE		

AgroBee 868 MHz
Indicaciones para su correcta instalación

Altura
Coordinador altura mínima de: calle subvencionada 10 m
Ónimo módulo altura mínima de: calle pavimentada 10 m
Módulo receptor altura mínima de: sin cable

Visibilidad
Caracter: visión directa entre a tierra.

Distribución directa entre sistemas
Comunicación directa del coordinador a los módulos, comunicación mediante receptor
Coordenadas Módulo: 48° 42' 38.00" W 34° 42' 17.00" N UTM 14 Q

 Distribución instalación

INSTALLATION MÓDULOS

The AgroBee-L modules have the antenna integrated into the module, so they are installed on top of a post.

For good radio communication, it is very important to place the modules in areas free of vegetation, walls, and metal structures.

The minimum recommended height to place the module is 4.5 metres from the ground. If there are tall crops (corn, trees, ...) this minimum height of the module must be increased by 2 metres above the height of the crop. In all cases, it must always have direct visibility with the controller's antenna that sends the information (coordinator located in Agrónic). The 7 metres of cable supplied already include these assembly recommendations.

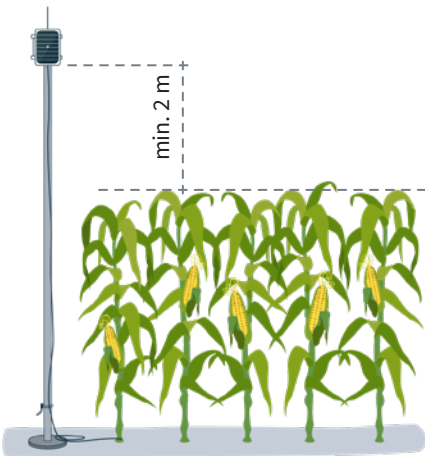
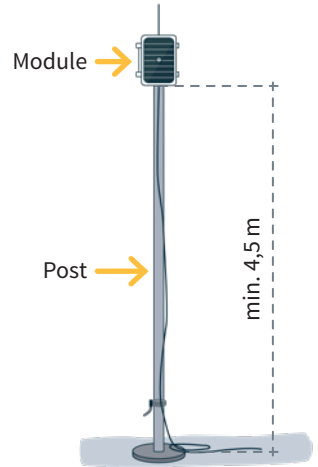

To increase the coverage, and if necessary, the best system is made by raising the module as high as the length of the cable allows.

The modules with solar panels must be placed orienting the panel to the South (Northern hemisphere) or North (Southern hemisphere) to obtain the best solar coverage.

To keep it watertight, it is necessary to always leave the lid closed.

The modules can be fixed on a 35 to 45mm post by means of the support and flange, incorporated (Endless stainless steel clamp, measure 32-50mm DIN3017) in such a way that the cable output passes through the inside of the post.

It is recommended to install it on folding or extendible posts for easy access to the module.

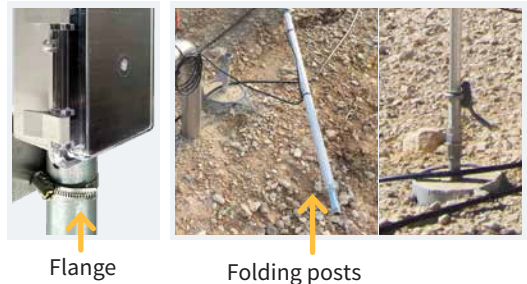

Inputs and Outputs

DIGITAL INPUTS

There is 1 digital input in an AgroBee-L 3MA module, which can function either as a digital input or a counter/rain gauge input. When the input is connected to a counter, the minimum time between pulses must be 0.1 seconds and an anti-bounce filter may be enabled in order to avoid accumulating undesired pulses. Maximum allowed distance between AgroBee-L module and a digital sensor or meter is 50m.

The digital input's wire connection is coloured Purple. The common wire input is the Grey-pink one.

ANALOG INPUTS

This model has up to 3 analog inputs for reading a maximum of 3 4-20 mA (or 1 0-20V sensor plus 2 4-20 mA sensors) and managing them. For said module, these inputs are the wires: A1-White, A2-Yellow, and A3-Blue, respectively. This module also has three common wires: Brown, Grey and Red. There is one for each sensor.

There are three cables for distributing power independently for each sensor: V1-Green, V2-Pink, and V3-Black.

IMPORTANT

- To obtain the reading through the White-A1 wire (output of the sensor in question), the corresponding sensor must be supplied through the Green-V1 wire.
- The black switch is on the inside of the controller (see image) allows you to select if sensor 1. Delivers voltage between 0-20 V or a current between 0-20 mA (0-2 V). Place the switch to the right toward the voltage input or to the left for the current.

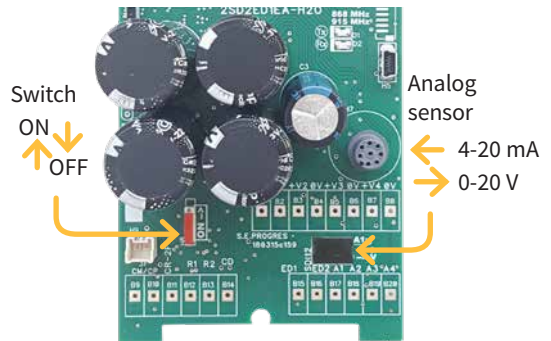

CONNECTION

Said module is provided with a cable tube that allows for different connections to be made more easily without the need to access the interior of the module:

- 3MA - 11-wire tube

To ensure the tightness of the module's cable connections, it is recommended to use watertight terminals. The connection through these terminals must be made without stripping the cable's wires. 3MA - 11-wire tube.

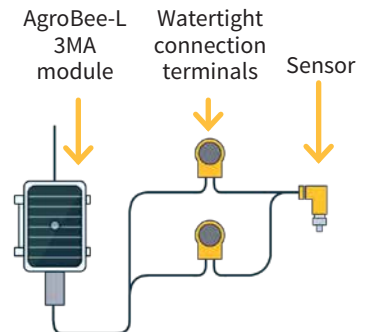

3MA			
Wire colour	ID	Function (3 sensors + digital input)	
White	A1	Analog input sensor 1	
Brown	0V	Common Power Sensors	
Green	V1	Power supply sensor 1	
Yellow	A2	Analog input sensor 2	
Grey	0V	Common Power Sensors	
Pink	V2	Power supply sensor 2	
Blue	A3	Analog input sensor 3	
Red	0V	Common Power Sensors	
Black	V3	Power supply sensor 3	
Purple	D1	Digital Input 1	
Grey-pink	CD	Common input	

The cables of the different tubes will come identified by colours and numbers. Connect them according to the following table and according to their functionality.

The 3M Scotchlok series (www.3m), ES Caps from TYCO (www.tycoelectronics.com), or Cellpack resin splicing and junction kits (www.cellpackiberica.com) can be used as connecting elements.

Settings





For any AgroBee-L module to enter the correct operating mode, you must have an Agrónic controller (Agrónic 2500, Agrónic 4500, Agrónic 5500 and Agrónic Bit Con) with the AgroBee-L option installed, which includes the internal coordinator and an antenna with 10 metres of cable. This can be verified by doing the following in the controller:

Consult → Communication → AgroBee-L → Status: Correct



In the same way, a module must be configured to communicate with the Agrónic with which you want to associate it. To do this (if the module is not already configured at the factory) you must use the Module Reader (or Agronic Radio Reader, LAR) consisting of a screen and four keys, that is connected to the AgroBee-L module through the only connector visible on the inside.

A wireless module reader is also available that allows you to perform functions without the need for a cable. Consult the wireless AgroBee Reader manual to learn about the steps to link it to the controller.

Press the  key to enter the main menu. Use the  and  keys to change the options within the menu. Use the  key to enter the selected menu option. Use the  key to return to the previous hierarchy's menu.

You will see the following options in the main menu:

- Consult controller
- Consult communications
- Consult digital and analog inputs
- Communication parameters
- Input-Output parameters
- Various parameters

NOTE

Once the AgroBee-L module is linked with an Agrónic, all the consultations and parameters are accessible through the Agrónic.

CONTROLLER QUERY OF AN AGROBEE-L MODULE

General query menu of the module, where the following parameters are displayed:

- Module and serial number:
 - Module: It refers to the module number (1 to 20) according to the established communication parameters. There can only be one same module number for each Agrónic.
 - Serial number: Information regarding the controller. It comes from the factory.
- Battery voltage and solar panel:
 - Vbat: Battery voltage:
 - Panel+Supercapacitors: Maximum value: 3.4V; Minimum value: 2.2V
 - Panel+Battery: Maximum value: 4.2V; Minimum value 3.4V
 - Vsol: Voltage of the solar panel

These same data can be viewed in the Agrónic by accessing “Consult - Communications - AgroBee,” as you will see in the next section.

CONSULT COMMUNICATIONS IN AN AGROBEE-L MODULE

Communication consultation menu of the module, where the following parameters are displayed:

- Transceiver: Type of emitter installed in the module. It tells you if the module works at 868MHz/433MHz or 915MHz
 - RN2483 (868MHz/433MHz)
 - RN2903 (915MHz)
- Band and transmission mode:
 - Band: 868MHz, 433MHz, 915MHz
 - Transmission Mode: 1 to 18 (mode 5 will be set by default)

- Consult parameters of the communication type:
 - Channel: 1 to 13
 - Network code: It is usually the associated Agrónic serial number
 - BW: Bandwidth of the radio modulation (125KHz, 250KHz, 500KHz). It is set according to the transmission mode chosen in the communication parameters.
 - Radio modulation factor: SF7, SF8,..., SF12. It is set according to the transmission mode chosen in the communication parameters.
 - Communication status:
 - Status message:
 - Correct Communication
 - Network error
 - Communication error
 - Model error
 - Does not communicate
 - Signal-Noise ratio of the last received message: Reliable communication if >40%.
 - Time until next radio emission: time in [s]
 - Status of the last 16 communications (the previous communications appear on the right side of the screen):
 - 1: It indicates that the emission has been made and the correct information received in the last communication
 - 0: Indicates that the radio emission has been made, but the correct data has not been received or no data has been received

Part of this information is available through the Agrónic by accessing “Consultation | Communications | AgroBee”, where you can also see the query regarding the controller and the parameters of the communication.

CONSULT COMMUNICATIONS
 AgroBee-L 868
 Status: Correct
 Timing: 60”
 Channel: 01 TX Mode: 05
 Network code: 00001

CONSULT COMMUNICATIONS
 M01 (ns. 236) V1.00
 Status: Correct (40”)
 Level: 80% / 82%
 Vbat: 04.0 V Vsol: 05.8 V
 1111111111111111

CONSULT THE AGROBEE-L MODULE DIGITAL AND ANALOG INPUTS

Menu to check the status of digital inputs, counters, and 3MA inputs.

The information shown on the different screens is as follows:

- Consult digital inputs: For each of the digital inputs available to the module in question, its status is shown either as '0' (open contact) or '1' (closed contact).
- See accumulated counter sensors: The total number of pulses detected will be displayed for each digital input configured as a counter sensor. If this entry is not configured as a counter, the text 'N-A' (Not-Activated) will appear.
- See instant flow rate (time between pulses): The time in [ms] between the last 2 pulses detected will be displayed for each digital input that is configured as a counter sensor. If this entry is not configured as a counter, the text 'N-A' (Not-Activated) will appear.
- Consult digital ultrasonic sensors: For each of the available digital inputs, the value read is directly displayed and expressed in [mm]. If the sensor in question is not active, the text 'N-A' (Not-Activated) will appear.
- Check the supply voltage of the analog sensors: The value of the supply voltage sent to the active analog sensors is displayed in [mV].

From the Agrónic, press the '1' key in the module's consultation screen on the Agrónic to view the analog/digital inputs.

Nomenclature used in these queries:

- **EA** analog input values in mV an in 4-20mA format. 4mA=800mV and 20mA=4000mV. The number next to EA indicates the sensor number.
- **ED** status of digital inputs. With a '1' indicating that the contact is closed and a '0,' that it is open.
- **Vsen** value of the voltage in mV supplied to the sensors.







```
AgroBee-L 02 3MA
EA1: 963
EA2: 963
EA3: 963
Vsen: 12125
ED: 1
```

COMMUNICATION PARAMETERS OF AN AGROBEE-L MODULE

The following parameters are in the Communication Parameters menu of the Module Reader, which allow you to establish the communication of a certain AgroBee-L module with a controller:

- **Module** Module number in the network. It is used to distinguish all modules that may be associated with an Agrónic. The module number cannot be repeated in the same Agrónic:
 - 1 to 20 (timing in normal mode)
 - 1 to 10 (timing in priority mode)

- **Band** Frequency Band:
 - 868MHz or 915MHz (default value, depending on the model)
 - 433MHz (only available in models that also support 868MHz band)
- **Channel** Frequency channel number:
 - 1 to 13 (independent from the band used)
- **TX Mode** Transmission method. Set the radio's transmission and reception parameters.
 - 1 to 18 (mode 5 set by default):
 - Mode 1: The shortest coverage length permitting the lowest lag time
 - Mode 18: The greatest coverage length, but with the most lag time
- **Timing** 2 timing modes:
 - Normal mode (recommended): It is automatically set according to the chosen transmission mode, but always includes the communication of up to 20 modules. Value between 60" and 200".
 - Priority mode: It is automatically set according to the chosen transmission mode and includes the communication of up to 10 modules. Value between 30" and 100".
- **Network code** It differentiates the information from several controllers with the same communication parameters (band, channel, and transmission mode). The Agrónic serial number is assigned by default.

To modify any of the sub-menu's fields, press . The screen will display that you are in edit mode. Use the  and  keys to set the desired value. Confirm with  or dismiss with . Press  to exit the menu and access the previous hierarchy's menu, which will change the parameters and let them take effect.







For an AgroBee-L module to establish communication with a certain Agrónic, you must set, through the reader, the parameters that have just been described, according to those established in the Agrónic in question. In the Agrónic, you can modify these parameters in 'Parameters | Installer | Communications | AgroBee | Coordinator':

AgroBee-L
 Channel: 01
 Network code: 00001
 Timing: standard
 Band: 868MHz
 TX Mode: 05

INPUT-OUTPUT PARAMETERS OF AN AGROBEE-L MODULE

In the Input-Output Parameters menu of the Module Reader, you can set the parameters of the AgroBee-L module's different inputs and outputs, available through the following sub-menu:

- **Digital Inputs** Configuration of digital sensors or counters.
 - Configuration of functions of each of the available digital inputs:
 - Digital input
 - Counter
 - Anti-bounce filter: (default 300 ms) only applicable when digital input is setup as counter. A filter time between 0.0" and 10.0" can be fixed, and it represents the minimum time that a contact must be closed to count a new pulse. Same time is considered for all the inputs of the module. This filter time can only be setup by using the Module Reader (it cannot be setup from the programmer to which this module is linked).
- **Sensors** Configuration of analog sensors. You will have the following options for each of the available inputs (1 to 3):
 - Active / Non-Active Input
 - Input type (only for Sensor-1): 4-20mA (default) or 0-20V. There is also a black switch in the circuit that must be in the same position as the one set through this option.
 - Reading rate: 5min (default), 10min, 20min
 - Sensor's power supply: 5V, 12V (default)
 - Timing of the sensor's power supply: 250ms default, 500ms, 1s, 2s

To modify any of the parameter's fields, press . The screen will display that you are in edit mode. Use the  and  keys to set the desired value. Confirm with  or dismiss with . Press  to exit the menu and access the previous hierarchy's menu, which will change the parameters and let them take effect.

IMPORTANT

The detailed input/output parameters can also be entered in the Agrónic. In this case, the module will receive the parameters upon communicating with it. If not, and these parameters have been changed through the Module Reader in the same module, the Agrónic will receive and update said parameters.

To modify these parameters from the Agrónic, you must access "Parameters – Installer – Communications – AgroBee – Module." Specify the module number in the Agrónic network in question, after which you will see the following screens to modify the detailed parameters (see the Agrónic manual in question for more details).

AgroBee-L 01
Sensor 1 Active: [YES][NO]
Sensor: [4-20mA][0-20V]
Timing: 5'
Voltage: 12Vdc
Voltage time: 250 ms

AgroBee-L 01
Sensor 2 Active: [YES][NO]
Timing: 5'
Voltage: 12Vdc
Voltage time: 250 ms

AgroBee-L 01
Sensor 3 Active: [YES][NO]
Timing: 5'
Voltage: 12Vdc
Voltage time: 250 ms

VARIOUS PARAMETERS OF AN AGROBEE-L MODULE

In the Various Parameters menu of the Module Reader, you can select the language among Spanish, Catalan, English, French, Italian, and Portuguese.

From this menu, you can also completely erase the module's data, restoring it to factory settings, maintaining the serial number and the model.

Battery levels and radio signal/quality

You have already seen how to consult the different parameters of an AgroBee-L module through the Module Reader. In the Agronic to which the AgroBee-L module is associated, it also shows the battery information and radio link performance of said module.

Consultation → Communications → AgroBee-L →
(down and up arrow to go through the different modules)

The information provided is:

- Module number, serial number, and firmware version
- Signal level received by the Agronic and the module. It is displayed in % and indicates the level of the signal-to-noise ratio.
- Advisable/recommended value > 40%
- Vbat: Battery level in mV:
 - Module with panel + supercapacitors: VBat max = 3.4 V; VBat min = 2.2 V.
- VSol: Voltage level delivered by the solar panel.

Estimated battery life 3MA solar model

Battery life with standard communication rate mode 5: 60 seconds

Type	3MA
Panel + Supercapacitors + 2.4 Ah battery ⁽¹⁾	> 10 days

(1): The duration of the battery with its maximum charge and without recharging. This case can occur when the solar panel does not recharge the battery (with clouds or fog).

Battery life is approximate since there are several factors that can affect consumption. Frequent reading of digital sensors (when counters are configured) shortens the duration. Likewise, if a priority mode rate is set, the battery life will decrease.

Conversely, for the 3MA model, if a higher sensor reading rate is selected, the battery life will increase.

Battery replacement Place the 2.4 Ah battery in its location, having previously turned the module OFF. Respect the polarity of the connector.



TURNING OFF THE CONTROLLER

If a module does not find the Agronic with which it communicates, said module will follow its own course, and will send data every certain time, according to the established timing. However, in order to avoid possible collisions and/or interferences, the module will slightly offset the pre-established communication time. The consumption of an AgroBee-L module is practically unchanged due to the fact that it is not connected to any Agronic.

Updating the AgroBee-L module software

Whenever there is a new software version for an AgroBee-L module, the user can update it. To do this, you must perform the following steps:

- Have a computer with an Internet connection and a USB to miniUSB cable.
- Download the program “AgronicUpg” + “drivers” + update file (dfu) by typing this address bit.ly/actualizaragronic into the computer’s browser.
- Select and download the AgroBee-L folder.
- Go to the module and turn it off using the switch.
- Place the other switch inside the module in the recording position (by default, it is in the ‘Normal’ position).
- Connect the USB to the computer and the miniUSB to the module.
- Start up the module using the ON/OFF switch.
- On the computer, run the program “AgronicUpg”.
If you do not see the “Internal Flash” line on the screen as seen in the image, you must install the

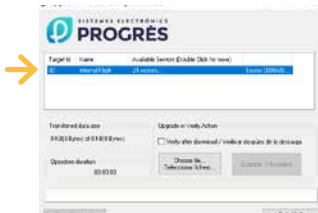
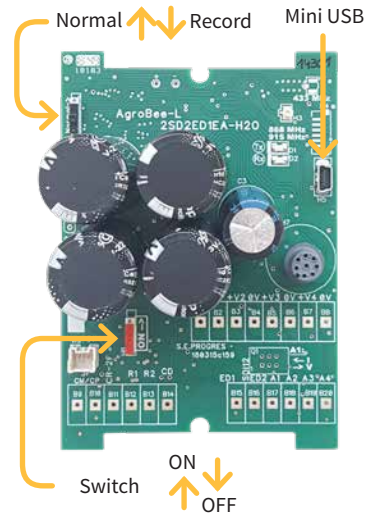

drivers. If you already have the drivers installed, skip to the next step.

- To install the drivers, go to the files you have downloaded and select the folder that corresponds to your Windows version. Run the file “dpinst_” and follow the steps. If you use Windows XP, call Progrés to help you with the installation.

- Press the “Choose file” button and select the file “xxx.dfu”. Once loaded, press the “Update” button and wait for the process to finish.
- Once the process is finished, the module is updated.
- To finish, turn off the module, disconnect the miniUSB cable, and place the second switch in the ‘Normal’ position.
- Finally, the module can be started up again.

Sistemes Electrònics Progrés, S.A.

Polígon Industrial, C/ de la Coma, 2 | 25243 El Palau d'Anglesola | Lleida | España

Tel. +34 973 32 04 29 | info@progres.es | www.progres.es

R-2169-5